



## Dear Members

If all goes smoothly, in approximately three weeks' time, we should all be enjoying long-awaited release, for good behaviour, from all Lockdown restrictions, although, at the time of writing, this could possibly be in jeopardy due to the growing threat seemingly now posed by the Indian variant.

Nevertheless, we should and must all remain optimistic that Boris and his advisors don't rain on our parade and will allow us to start living our lives again where we left off, also permitting us to reinstate regular Club meetings, which were so abruptly interrupted some 15 months or so ago.

As a start and as previously announced, there's a daytime Club meeting planned for Monday June 14<sup>th</sup> at our regular watering hole, the 'New Inn' in Heckfield. This will be held outside and numbers limited to 30. Steve, our landlord, has offered to reserve and arrange for us to occupy the tables and seating within the fenced area, adjacent to the car park which will ensure we can avoid mixing unnecessarily with other customers. In response to a request, made earlier, for names, **fifteen** members have so far indicated an interest in attending. If there are others who would like to do so, **please do let me have names soonest.** This is quite important, to avoid possible disappointment should attendance risk being oversubscribed. Realistically this is probably not very likely but much better to be safe than sorry.

Unfortunately, Covid restrictions, which will still be in force on the date of the planned first meeting, prevents any spontaneity in this instance, which is the reason why such cautious measures are being exercised. It's suggested that we aim to convene from around noon onwards.

Also, a Club Run, planned originally for Sunday May 23<sup>rd</sup>, but which had to be postponed due to inclement weather, has now been rescheduled for **Sunday 13<sup>th</sup> June**. Details of this have been publicised separately to all members and several have already 'signed up' for this second attempt. However, if there are other Members who would like to join the group setting off from Conkers Garden Centre, in Hatch, on the A30, or there are any questions or more information is required please email me at [trevorcedwards@icloud.com](mailto:trevorcedwards@icloud.com) or call me on 01344 775012.

Whilst on the topic of runs, events and similar activities there were just 10 entries for the IOW Virtual Tour, incorporating 60 questions, to be solved *en route*. Entrants were made up of 9 from the Austin Ten Drivers Club and 4 from NHAEG members. 3 of the NHAEG members were ATDC members as well. There were 6 completed sheets sent in and 2 of the non-finishers informed me that this type of event was not for them ! I presume that the others found it very difficult as well.

The winners were Fred and Chris Leach from Chateris in Cambridgeshire - ATDC members - with 60 points. The other scores were very close with one at 53 and the rest between 55 and 57. That made marking very tricky!

The feedback from those who completed the event has been very favourable, all saying that they thoroughly enjoyed it and A big 'Thank You' to Tony and Pat is overdue ! The low entry

was disappointing as there were a fair number in NHAEG that have been to the IOW and would no doubt have enjoyed renewing their acquaintance with the Island.

On a final, positive note, the weather, generally, appears to be taking a definite turn for the better now that meteorological Summer has arrived, so enjoy it whilst you can, after what was, by any yardstick, a pretty miserable Spring.

Take care and above all, continue to stay safe – motoring and health-wise!

Trevor E

## Integrated Trafficator and Indicator wiring

**Option 1** (negative earth): Use a single ‘toggle’ switch with two gangs and a single flasher relay. The trafficator circuit and indicator circuits are electrically isolated from one another on separate switch gangs, while being mechanically operated by the same knob/lever.

For positive earth reverse the 12v and earth connections. **Note:** relays might be specific to –ve or +ve earth – use the right type!

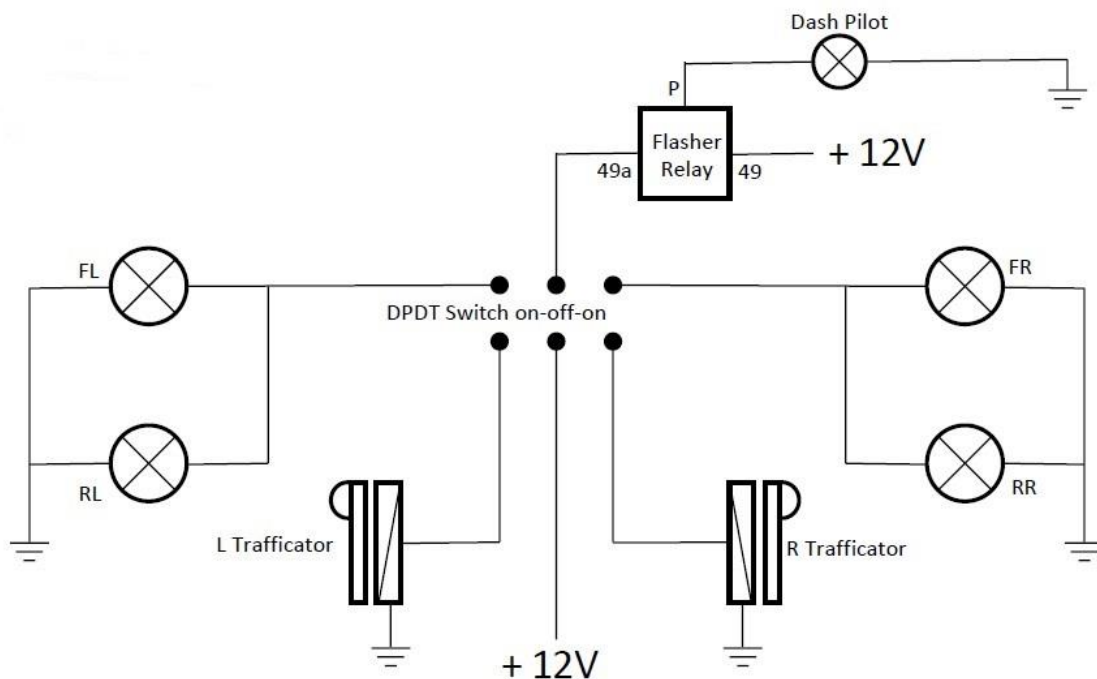

**Option 2** (negative earth): Use a classic trafficator or indicator switch and two flasher relays. If using the existing pilot light inside a trafficator switch it be necessary to REMOVE any connections from the bulb to the left and right switch circuits. Wire the pilot lamp directly to the two relays via diodes if using a single pilot (1N4003 type diodes are ideal for low wattage bulbs or LEDs). Optionally use two pilot lamps, one on each relay, which negates the need for diodes.

For positive earth reverse the 12v and earth connections **AND reverse the diodes** if using a single dash pilot.

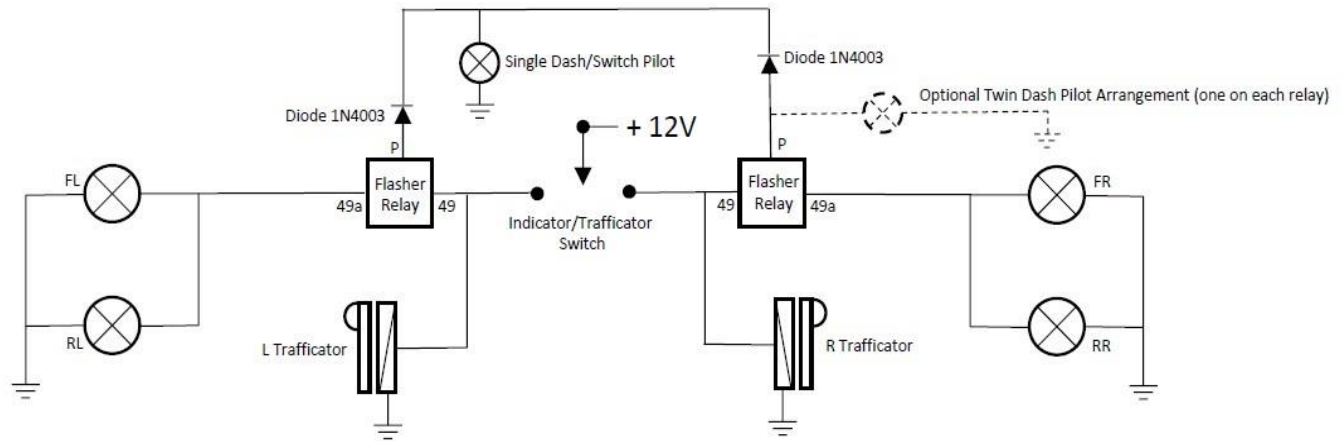

Thanks to Andy Seager

## Battery Care

A: maintain electrolyte level to approximately 1/4 inch above the plates, any higher than this is wasted, but it's very important not to let the level fall below the top of plates because it dramatically reduces the output of the battery to the extent of 5% per every 1/2 inch below top of plates. Check electrolyte level regularly, particularly if using the car on long runs because the A7 is not fitted with compensated voltage control, which means when the battery voltage exceeds 6-8 volts the plates will start to (gas off) and evaporate the distilled water.

B: keep the terminals free from corrosion, to clean excessive corrosion brush on a strong alkaline solution (domestic washing powder) and when refitting use a liberal smear of Vaseline or normal grease.

C: If possible use de-ionised distilled water for topping up battery cells, but acceptable substitutes are condensate from a domestic condenser tumble dryer or from a room de-humidifier.

D: Finally when disconnecting battery, always remove firstly the terminal connected to the cars bodywork (called the earth) if you remove the live terminal first and your spanner slips enough to make contact with the bodywork then this will result in a dangerous dead short.

Note. Whilst freezing temperatures will not affect a well charged battery, a discharged one can easily be damaged. So, best to keep your battery well charged in the winter using a permanently connected trickle charger.

copyright HA7C

## Fire Alarm

Car fires are scary and a leaking fuel hose can cause petrol to flow onto a hot exhaust and set fire to the car. We are aware that Ethanol in petrol can cause rubber to perish and as we are sensible people we treat petrol smells with extreme caution. Now consider what happens when an electric vehicle develops a fault when charging. When you have a minute to spare look up YouTube and search for electric car fires – now that is scary.

## A7 at Beaulieu



The 58th  
**National Austin 7 Rally**  
Beaulieu - Sunday 4th July 2021

A great day out for enthusiasts, visitors and families  
All Austin 7s and pre-1980 cars welcome.  
You don't have to be a club member!

\* This year's special theme:  
Coach built & fabric-bodied Austin 7s

\* Huge Austin autojumble

\* Saturday: morning visit to Exbury Gardens and Steam Railway; afternoon drive through New Forest; evening gathering

\* Sunday: displays, autojumble, concours, driving tests and awards.

\* On-site camping available

\* Ticket includes entry to the National Motor Museum, Palace House and Gardens

Enquiries to:  
Ian Nelson  
ian.nelson@btinternet.com  
07803 888585

PRE-WAR AUSTIN SEVEN CLUB  
A7

The Austin Seven Rally at Beaulieu is on the 4th July 2021 below is a link to the application and more information.

Austin 7s of all types from all over the United Kingdom and Europe gather for an event full of activities, including an Austin Autojumble, driving skills tests and concours competition with plenty of trophies to be won.

All Austin 7s are welcome (no need to be a 750 Motor Club Member). Other Austins and pre-1975 cars are also welcome - but all must be registered with the organiser :

<https://www.pwa7c.co.uk/downloads/2021BeaulieuRally.pdf>

## The Good old days

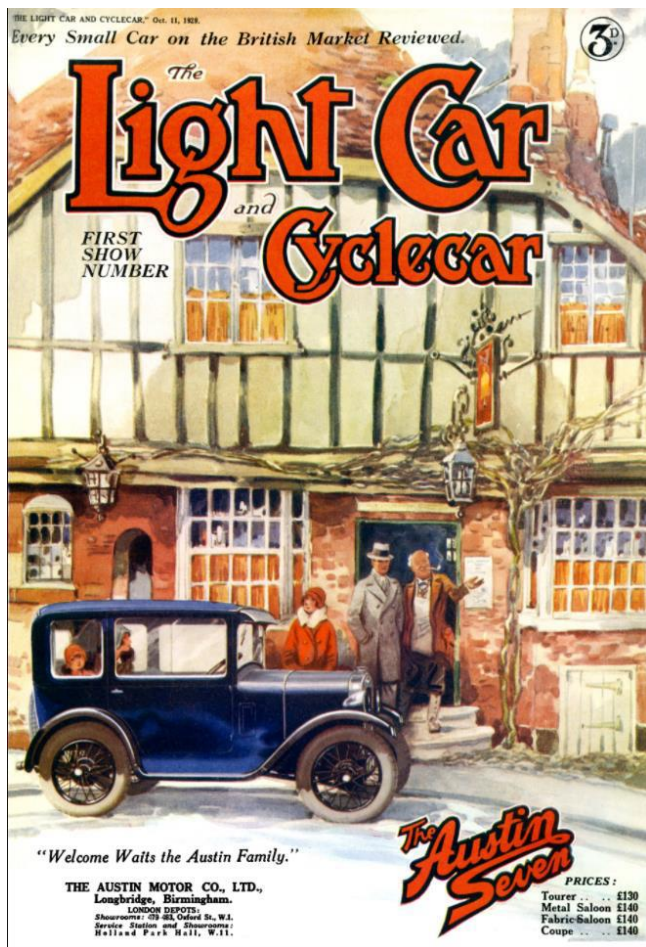

Although the price of a new Austin Seven in 1929 was just £130 -£140 remember that the average salary in early 1930 was about £1 11s (shillings) 8d (pence) for a week of just over 50 hours, or roughly a shilling an hour. This rate however increased by the end of the decade, standing at £1 19s 5 1/2 d by October 1939.

Events – All dates subject to Change !

## Haynes Motor Museum

The Breakfast Club meetings at the Haynes Motor Museum in Sparkford, Somerset, will resume in June 2021. The gatherings will be on the first Sunday of the month for post 1980 cars and the second Sunday for pre-1980 vehicles. Admission costs £5 by pre-booked tickets. More information on [www.bit.ly/3jVsARQ](http://www.bit.ly/3jVsARQ)

Club meeting 14th June Outside at the New Inn – meet at noon.



## Club Run Sunday 13<sup>th</sup> June Army Flying Museum

Meet at Conkers garden centre at 10:15.

## The British Motor Show is back !!!

The iconic British Motor Show returns in 2021, with a new format and a new location :

**When** : Thursday 19<sup>th</sup> – Sunday 22<sup>nd</sup> August

**Where** :Farnborough International Expo Centre

**How Much** :Tickets: Concessions £13.90, Adults £ 18.50

**Details at** :. <https://thebritishmotorshow.live/>

## Basingstoke Festival of Transport – 22<sup>nd</sup> Aug 2021

The Basingstoke Festival of Transport will be held at the War Memorial Park, Basingstoke, RG21 4AG. Parking is available at Old Common, London Road (use RG21 4BY and follow the parking signs) for £2. NHAEG is organising a parking area for club members and those wishing to attend should complete the Car Club Registration Form which may be obtained from Trevor Mulford (01252) 620435 or by email [trevormulford1942@gmail.com](mailto:trevormulford1942@gmail.com)

## The Beaulieu 2021 International Autojumble, 4-5<sup>th</sup> September

### Hartley Witney Festival – 4<sup>th</sup> September

This will include : Procession / Classic Cars / Arena Events / Stalls / Catering / Animal Farm / Morris Dancers etc. If you wish to show your car, please contact:

Trevor Mulford (01252) 620435 or by email [trevormulford1942@gmail.com](mailto:trevormulford1942@gmail.com)

## Classic Motor Show NEC Birmingham, 12-14<sup>th</sup> November

### The Austin 7 Centenary Celebration & Rally

This is due to take place between 19<sup>th</sup>-24<sup>th</sup> July 2022 at the Fire Service college, Moreton-in-Marsh, Gloucestershire. As provided in the magazine of the Scottish Austin Seven Club. For more information, please visit [www.a7centenary.com](http://www.a7centenary.com)

Stay safe

NHAEG Committee